

1.5 Tonne

Powered Hand Pallet Truck



Model: GPPT 1500 Edge



7 reasons

why Godrej Powered Hand Pallet Truck is the right choice to improve productivity and safety of your material handling operations

1 Works in a compact space like a Hand Pallet Truck

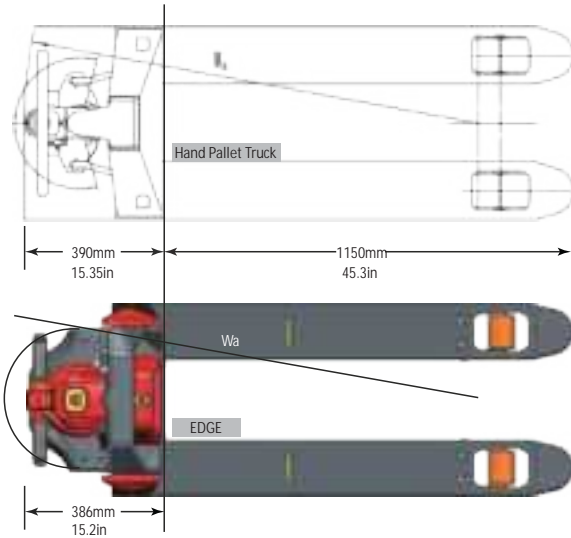

- γ The short body length of truck (L2=380mm) is even smaller than Hand Pallet Truck. It provides the shortest turning radius of 1274 / 1336 mm with lifted/lowered forks and makes the truck extremely compact and ideal for use in confined spaces of retail stores, elevators or business centers.

2 Robust & smart design of chassis ensures long life of truck



- γ Full length double sided C-shape reinforcements of forks significantly increase strength and rigidity of frame.
- γ Strong steel apron protects operator's feet during work and secures truck's components from collision with objects.

3 Robust performance drives productivity



- γ Load capacity of 1500 kgs, rugged drive unit and high gradeability make the truck an ideal choice for rigorous short distance transfer duties, clearing of staging areas and operating on ramps.

4 Ergonomic and full function control handle facilitates ease of operation

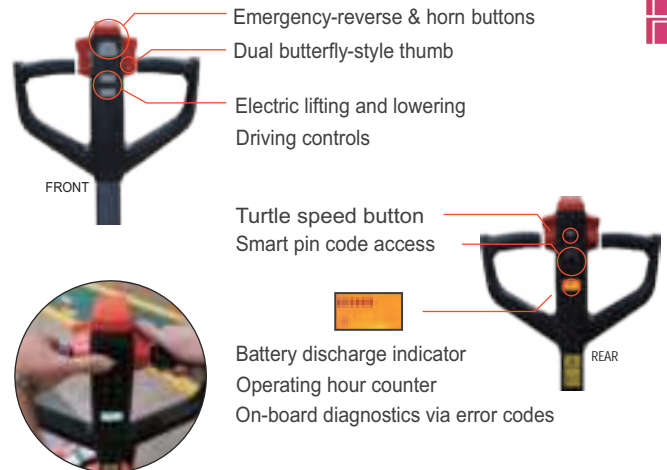

- γ The function of driving with tiller in the vertical position helps with operations in confined areas without sacrificing safety

5 Various safety features ensure stress free working

- γ Powered traction and lift minimizes the operator's physical input and provides a highly productive and stress free working environment.
- γ Truck is equipped with an electromagnetic failsafe parking brake.
- γ Robust metal cowling protects the drive unit and components, while the low profile chassis protects the operator's feet.
- γ The long low mounted tiller arm places the operator at a safe yet comfortable working distance from the truck.

6 Easy to change & easy to charge smart Li-Ion Battery imparts flexibility in operations

- γ Edge is equipped with maintenance-free lithium-ion battery, that facilitates opportunity charging without impacting life of battery.

- γ Smart battery positioning and lock for great fixation and safety.



- γ Light weight lithium-ion battery for easy changeover

7 Maintenance friendly service layout

- γ Convenient and fast access to any component of truck.
- γ There are no hoses or pipes used in hydraulic lifting circuit thus eliminating potential problems related to leakages through connectors.
- γ The truck is equipped with MOSFET controller and CAN-bus technology that makes the diagnostic and troubleshooting easier



Specification of Godrej 1.5 Ton Powered Hand Pallet Truck with Li-ion Battery

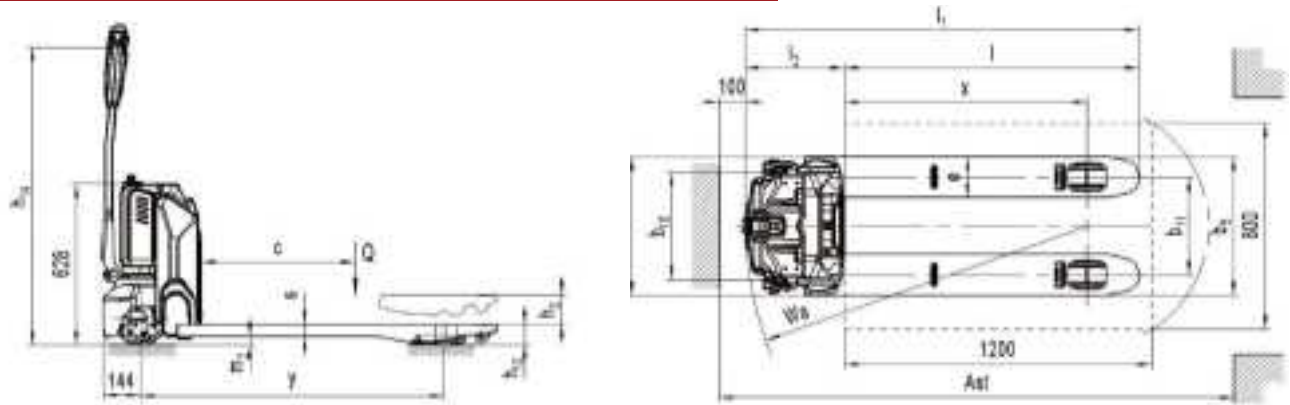

TECHNICAL SPECIFICATION

TECHNICAL SPECIFICATION				
Characteristics	Manufacturer		Godrej	
	Model Designation		GPPT 1500 Edge	
	Operation Type		Pedestrian	
	Load Capacity	Q	Kg	1500
	Load Centre	C	mm	600
	Axle centre to fork face (Load distance)	X	mm	947
	Wheel Base	Y	mm	1185
Weights	Unladen weight incl. battery	-	123	126
	Axle loading	w. load Drive / Load	500 / 1123	626 / 1000
		w.o. load Drive / Load	96 / 27	99 / 27
Wheels & Tyres	Wheels Type		Polyurethane	
	Wheel size	Drive	mm	210 x 70
		Load	mm	80 x 70
		Castor Wheel	mm	80 x 30
	No. of wheels	Drive / Load / Castor wheel		1 x 4 x 2
Track Width at Load wheel	b11	mm	380	525
Dimensions	Lift Height	h3	mm	115
	Height of tiller in drive position min / max	h14	mm	700 / 1160
	Lowered Forks Height	h13	mm	80
	Overall Length	l1	mm	1530
	Lowered Headlength	l2	mm	380
	Overall width	l2	mm	540/685
	Fork dimension	Length x Width x Thickness	mm	1150 x 160 x 47
	Max. width across forks	b5	mm	540 / 685
	Ground clearance at centre of wheelbase	m2	mm	33
	Aisle width with pallet 1000X1200 across forks	Ast	mm	2130
	Aisle width with pallet 800X1200 along forks			2000
Turning Radius	Wa	mm	1330	
Performance	Travel speed	with load / without load	Km/h	4.6 / 4.8
	Lift speed	with load / without load	m/sec	0.02 / 0.025
	Lowering speed	with load / without load	m/sec	0.05 / 0.04
	Max. gradeability	with load / without load	%	4 / 16
	Service brake			EM
Electrics	Drive motor, S2 60 min rating		kW	0.65
	Lift motor, S3 10% rating		kW	0.5
	Battery (Li- Ion)	Voltage	V	24
		Capacity	Ah	20
	Battery weight		Kg	4.6
Misc.	Type of drive control			DC Speed Control
	Sound level at driver's ear acc. to EN 12053	dB(A)		<70
	Steering type			mechanical

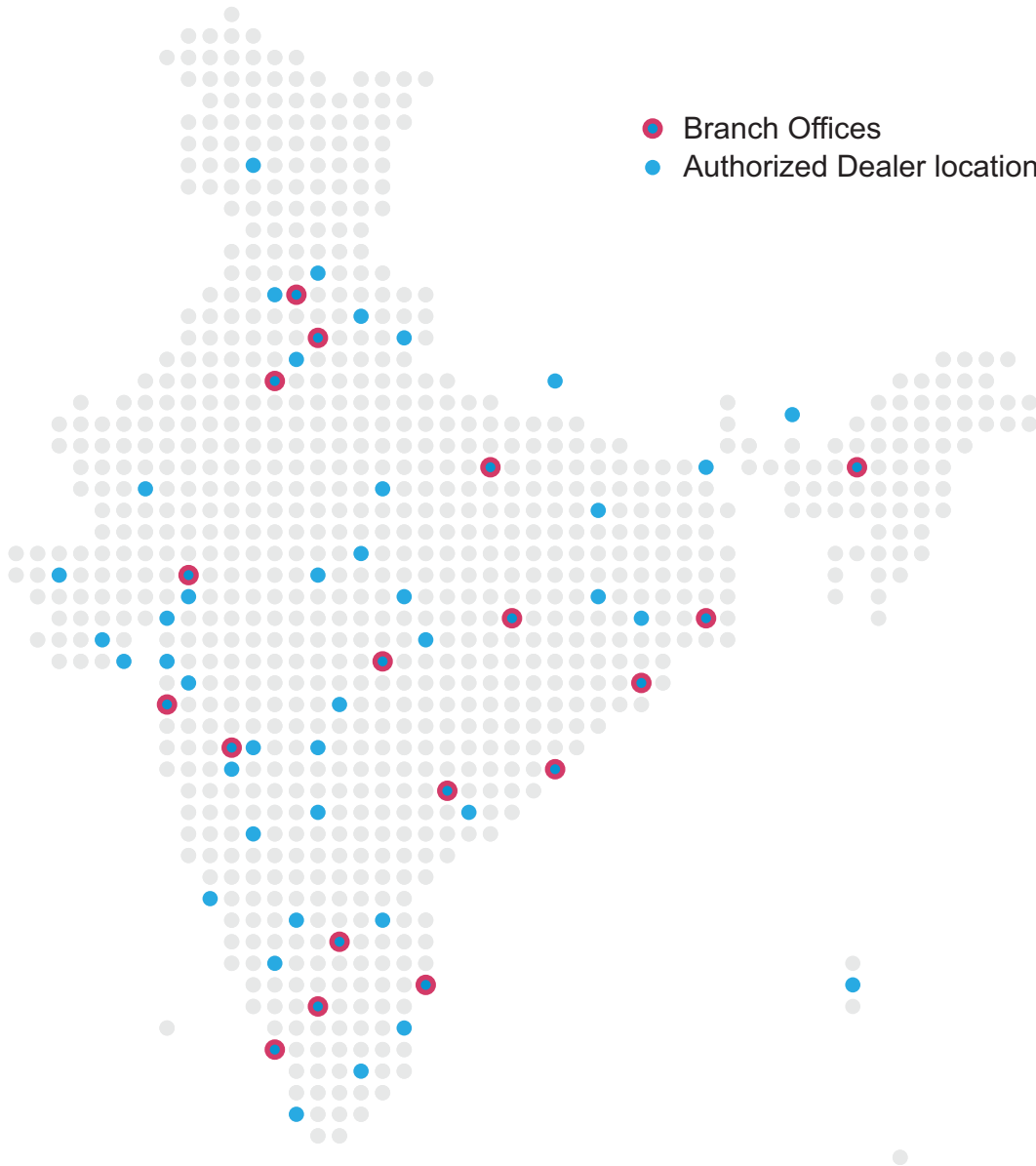

● Branch Offices
● Authorized Dealer location



*With our widespread network,
we are lifting businesses across the country.*



GODREJ & BOYCE MFG. CO. LTD.

Plant 16, Pirojshanagar, vikhroli, mumbai 400079.

• Tel: +91 22 67 96 4660 • Fax: +91 22 6796 1519 • E-mail: mhemktg@godrej.com • URL: <http://godrejmh.in>

Branches & Service Centres

Y Ahmedabad: 079 6606 0646
Y Bangalore: 080 6647 2251
Y Bhubaneswar: 0674 2374627
Y Chandigarh: 0172 5012525
Y Chennai: 044 6654 4431
Y Coimbatore: 0422 2545799/599

Y Delhi: 011 66507340
Y Guwahati: 03612 468242
Y Hyderabad: 040 6643 1203
Y Indore: 0731 4069335
Y Jaipur: 0141 6701443
Y Kochi: 0484 6612777

Y Kolkata: 033 6601 3771
Y Lucknow: 0522 6754980
Y Mumbai: 022 6796 1291
Y Pune: 020 6625 5121
Y Raipur: 0771 6606606
Y Vizag: 08912746511

To find out more about what's new at Godrej Material Handling, check out www.godrejmh.in

