

Articulated Forklifts





SET A NEW PACE

WITH THE WIDE RANGE OF GODREJ ARTICULATED FORKLIFTS

When it comes to running your supply chain, everyday is a race to move more product with optimum productivity, efficiency, and safety.

Godrej Articulated Forklifts combine the best of three types of lift trucks.



Speed and flexibility of a counterbalance truck

Lift height of a reach truck

Aisle performance of a VNA turret truck

Godrej Articulated Forklift - One truck that does it all!

A RANGE OF SOLUTIONS

Godrej Articulated Forklifts have capacities from 1.2 to 2 tonnes, lift height up to 12.5 m and battery capacities from 520 to 900 Ah. They offer tailor-made solutions for all your material handling requirements.



1.2 Tonne

1.5 Tonne

1.8 Tonne

2 Tonne



SIMPLIFY TASKS

IN NARROWER AISLES WITH VERSATILE ARTICULATED FORKLIFTS

Capable of working in confined areas with aisle space as less as 1.7 metres.



Less Aisle = More Pallet Postions

MULTIPURPOSE WORKHORSE FOR TOTAL FLEXIBILITY

Transfer from lorry-to-rack and rack-to-lorry in a single handling operation and boost productivity.





GO HIGHER AND NARROWER

WITH UNMATCHED CONFIDENCE



Mast top view



The slim mast in Godrej Articulated Forklifts curbs mast sway, enabling the mast to go higher and be more stable. This makes it possible to handle unprecedented capacities, maximizing pallet locations in your warehouse.



Unmatched visibility and responsive controls on the articulated series let you stack it just right.

More stable than counterbalance forklifts due to its inverted Stability Triangle

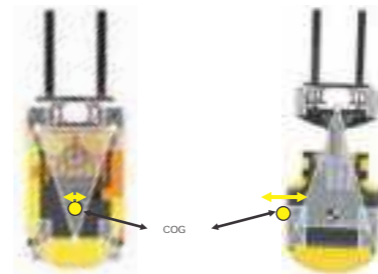

Counterbalance Forklift

Articulated Forklift

The centre of Gravity (CoG) of a forklift must always remain within its 'Stability Triangle'. A forklift becomes unstable when its CoG moves outside the Stability Triangle.

In the Articulated Forklift, the CoG is near the base of the triangle, while in counterbalance trucks, it lies near the narrow apex.



TAKE CONTROL

WITH EXCELLENT ERGONOMICS AND COMFORT FOR THE OPERATOR



Comfortable seat with retractable seat belt



Generous knee and leg room



Steering and seating position with all controls within reach

KEEP GOING

WITH PROVEN TECHNOLOGY AND EASY SERVICEABILITY

Comfortable access to critical components ensures that the trucks can be serviced with ease.



Fork pockets for easy removal of battery

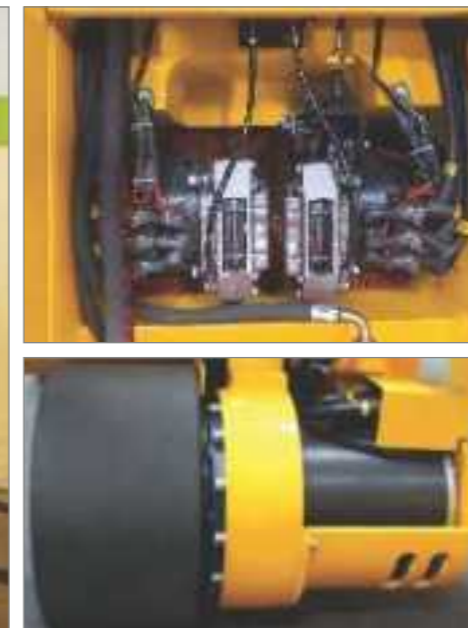

Easy access to AC drive motors

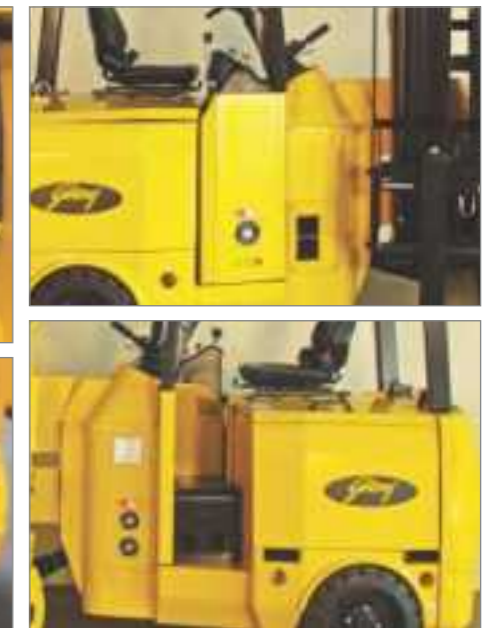

Single allen key required to access control units



Technical Data

Parameter			GA 120 E3	GA 150 E3	GA 180 E3	GA 200 E4	GA 200 E4 HL
Capacity	(kg)		1200	1500	1800	2000	2000
Load centre	(mm)		500	500	500	500	600
Power source			Traction battery	Traction battery	Traction battery	Traction battery	Traction battery
Service weight (without mast & battery)	(kg)		4135	4835	5070	5340	5900
Travel speed (adjustable) (laden / unladen)	(kph)		11 / 12	11 / 12	11 / 12	12 / 12.5	12 / 12.5
Lift speed (laden / unladen)	(m/s)		0.30 / 0.50	0.30 / 0.50	0.30 / 0.50	0.30 / 0.50	0.30 / 0.50
Lower speed (laden / unladen)	(m/s)		0.38 / 0.29	0.38 / 0.29	0.38 / 0.29	0.5 / 0.19	0.4 / 0.3
Tilt range (forward / backward)	(deg)		1 / 3	1 / 3	1 / 3	1 / 3	1 / 3
Overhead guard height	(mm)	(g)	2290	2290	2290	2260	2260
Seat height	(mm)	(f)	1220	1220	1220	1220	1220
Cab floor height	(mm)	(e)	700	700	700	700	700
Minimum ground clearance (rear)	(mm)	(d)	120	120	120	120	120
Minimum ground clearance (front)	(mm)	(j)	60	60	60	60	60
Lost load centre	(mm)	(a)	270	270	270	270	270
Overall length to face of forks	(mm)	(c)	2500	2600	2610	2800	2890
Wheelbase	(mm)	(b)	1780	1780	1820	1840	1890
Chassis width	(mm)	(h)	1140	1140	1300	1320	1520
Maximum gradient	(%)	(%)	10	10	10	15	15
Front chassis articulation angle	(m), (deg)	(m)	± 105	± 105	± 105	± 104	+/-100
Rotation angle	(deg)		210	210	210	208	200
Lift motor rating	(kW)		12	12	12	12	12
Drive motor rating	(kW)		8	8	8	6 x 2	6 x 2
Wheel size (dia x width), (front / rear)	(mm)		406 x 200 / 460 x 180	406 x 200 / 460 x 180	406 x 180 / 460 x 185	305 x 150 / 460 x 200	305 x 150 / 460 x 230
Battery type	(V / Ah)		48 / 520	48 / 520	48 / 650	48 / 780	48 / 900
Min. battery weight	(kg)		800	800	870	1100	1300
Control type			MOSFET control with AC induction motor	MOSFET control with AC induction motor	MOSFET control with AC induction motor	MOSFET control with AC induction motor	MOSFET control with AC induction motor

All dimensions and specifications are subject to variations within ± 15%

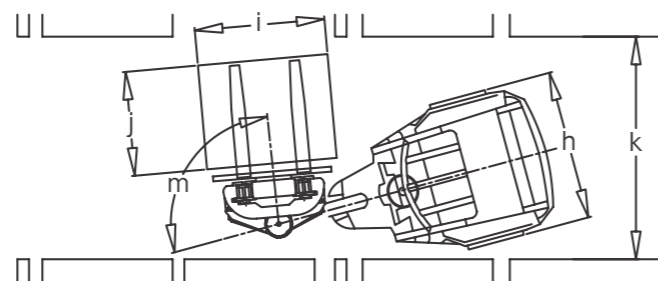
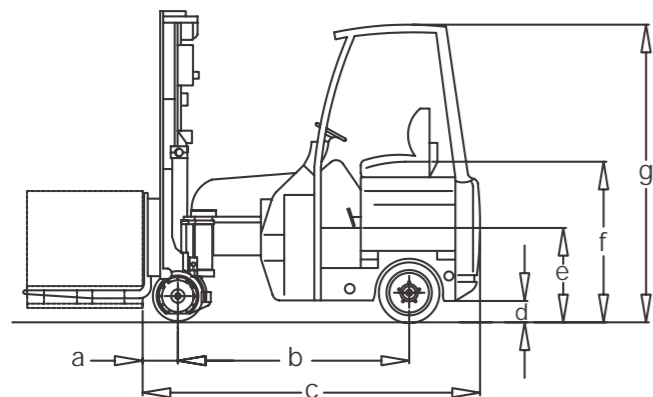

Mast Specifications

Description	Mast Type	Model	Base load capacity (kg) @ load centre (up to 3300 height)		MFH (mm)	O AHL (mm)	*O AHR (mm) without LBR	**Free lift (mm) without LBR	Derated capacity (kg) at MFH @ load center (with side-shift)		Std battery (V/Ah)
			500 mm	600 mm					500 mm	600 mm	
Godrej 1.2T- 3 Wheel Articulated Forklift Model GA 120 E3	2 STAGE CVM	GA 120 - E3 - 46	1200	1000	4600	3350	5150	0	975	850	48 / 520
	2 STAGE CVM	GA 120 - E3 - 55	1200	1000	5500	3800	6050	0	800	625	48 / 520
	3 STAGE CVT	GA 120 - E3 - 50	1200	1050	5000	2599	5860	1750	950	800	48 / 520
	3 STAGE CVT	GA 120 - E3 - 60	1200	1050	6000	2982	6860	2117	850	700	48 / 520
	3 STAGE CVT	GA 120 - E3 - 71	1200	1050	7150	3466	8010	2550	650	500	48 / 520
Godrej 1.5T- 3 Wheel Articulated Forklift Model GA 150 E3	2 STAGE CVM	GA 150 - E3 - 46	1500	1300	4600	3350	5150	0	1275	1150	48 / 520
	2 STAGE CVM	GA 150 - E3 - 55	1500	1300	5500	3800	6050	0	1100	975	48 / 520
	3 STAGE CVT	GA 150 - E3 - 50	1500	1350	5000	2599	5860	1750	1250	1100	48 / 520
	3 STAGE CVT	GA 150 - E3 - 60	1500	1350	6000	2982	6860	2117	1150	1000	48 / 520
	3 STAGE CVT	GA 150 - E3 - 71	1500	1350	7150	3466	8010	2550	950	800	48 / 520
Godrej 1.8T- 3 Wheel Articulated Forklift Model GA 180 E3	2 STAGE CVM	GA 180 - E3 - 46	1800	1550	4600	3350	5150	0	1525	1300	48 / 650
	2 STAGE CVM	GA 180 - E3 - 55	1800	1550	5500	3800	6050	0	1350	1100	48 / 650
	3 STAGE CVT	GA 180 - E3 - 50	1800	1600	5000	2599	5860	1750	1550	1350	48 / 650
	3 STAGE CVT	GA 180 - E3 - 60	1800	1600	6000	2982	6860	2117	1350	1150	48 / 650
	3 STAGE CVT	GA 180 - E3 - 71	1800	1600	7150	3466	8010	2550	1150	950	48 / 650
	3 STAGE CVT	GA 180 - E3 - 82	1800	1600	8200	3949	9060	3083	950	750	48 / 650
	3 STAGE CVT	GA 180 - E3 - 90	1800	1600	9000	4199	9860	3350	800	600	48 / 650
Godrej 2T- 4 Wheel Articulated Forklift Model GA 200 E4	3 STAGE CVT	GA 200 - E4 - 50	2000	1850	5000	2437	5550	1912	1750	1600	48/780
	3 STAGE CVT	GA 200 - E4 - 60	2000	1850	6000	2804	6550	2279	1575	1425	48/780
	3 STAGE CVT	GA 200 - E4 - 71	2000	1850	7150	3175	7700	2712	1325	1175	48/780
	3 STAGE CVT	GA 200 - E4 - 82	2000	1850	8200	3770	8750	3245	1175	1025	48/780
	3 STAGE CVT	GA 200 - E4 - 90	2000	1850	9000	4037	9550	3512	1000	850	48/780
	3 STAGE CVT	GA 200 - E4 - 94	2000	1850	9400	4170	9937	3633	900	750	48 / 780
Godrej 2T- 4 Wheel Articulated Forklift Model GA 200 E4 HL	3 STAGE CVT	GA 200 - E4 - 82 - HL	2000	2000	8200	3770	8750	3147	1550	1400	48/900
	3 STAGE CVT	GA 200 - E4 - 90 - HL	2000	2000	9000	4004	9550	3467	1450	1300	48/900
	3 STAGE CVT	GA 200- E4 - 100-HL	2000	2000	10000	4404	10550	3867	1250	1100	48/900
	3 STAGE CVT	GA 200- E4 - 106-HL	2000	2000	10600	4644	11150	4107	1125	1000	48/900
	3 STAGE CVT	GA 200 -E4 - 110-HL	2000	2000	11000	4804	11550	4267	1000	900	48/900
	3 STAGE CVT	GA 200 - E4 - 120-HL	2000	2000	12000	5204	12550	4667	750	600	48/900
3 STAGE CVT	GA 200 - E4 - 125-HL	2000	2000	12500	5404	13050	4867	650	500	48/900	

*Add 750 mm in case LBR is required. **Subtract 750 mm in case LBR is required.

Aisle requirements

Length x Width (2 Pallets) in mm.	Min. Clear aisle (k)* GA 120 E3	Min. Clear aisle (k)* GA 150 E3	Min. Clear aisle (k)* GA 180 E3	Min. Clear aisle (k)* GA200E4	Min. Clear aisle (k)* GA200E4-HL
1200 x 1200	1950 mm	1950 mm	1950 mm	2000 mm	2150 mm
1000 x 1200	1700 mm	1700 mm	1750 mm	1800 mm	1950 mm
1200 x 1000	1850 mm	1850 mm	1850 mm	1900 mm	2050 mm
1200 x 800	1800 mm	1800 mm	1850 mm	1850 mm	2050 mm
Clear transfer aisle	2700 mm	2700 mm	2700 mm	2700 mm	2850 mm
End transfer aisle	750 mm	750 mm	750 mm	750 mm	850 mm

Note: The above mentioned aisle spaces are the optimum dimensions for operating the equipment by trained drivers. Wherever possible, an additional clearance of 200 mm is recommended to facilitate comfortable driving.



STANDARD OFFERINGS

The Godrej Articulated Forklifts come with the following standard fitments to boost productivity:



- | | | |
|----------------|--------------------------------------|-------------------------------|
| 1. Headlights | 6. Horn | 11. Side shift |
| 2. Rear light | 7. Battery Discharge Indicator (BDI) | 12. Load back rest |
| 3. Brake light | 8. Emergency stop mushroom button | 13. PU drive tyre(s) |
| 4. Seat belt | 9. Parking brake | 14. Solid rear tyres |
| 5. Mirrors | 10. Forks | 15. Battery with fork pockets |



PERFORMANCE ENHANCING OPTIONS

A wide range of options are available with Godrej Articulated Forklifts to meet your specific application needs.



1. Mast / fork mounted camera and colour monitor



2. Biometric access

3. Reverse sensor

4. Impact detector



5. Battery changing rollers and trolley*



6. Auto fill system

- 7. Height restrictions
- 8. Rack assist feature
- 9. Operator Presence Switch (OPS)
- 10. Non-marking tyres (rear wheels only)
- 11. Freezer conditioning
- 12. Blue light

*In lieu of fork pockets.



Our Range



3-wheel Electric Forklifts
0.8 to 1.6 tonne



Electric Forklifts
1 to 5 tonne



Diesel Forklifts
1.5 to 4 tonne



Diesel Forklifts
5 to 10 tonne



Diesel Forklifts
12 to 25 tonne



Dock Leveler
9 and 12 tonne



Hand Pallet Truck
2.5 tonne



Powered Pallet Truck
1.5 and 2 tonne



Electric Stacker
1.2 and 1.5 tonne



Reach Truck
1 and 1.2 tonne



Platform Truck
2, 3, and 4 tonne



Tow Truck
2, 5, and 6 tonne
(Stand up & Sit down model)



CROWN
Warehousing
Equipment



KOMATSU
Forklifts



Tennant
Industrial Cleaning
Equipment



HUBTEX
Side Loaders



MERLO



DISTRIBUTION: Our network of 17 company owned branches brings us closer to customers across India. This also gives us the edge to distribute equipment from global giants including Crown, Komatsu, Merlo, Tennant, and Hubtex in India.

GODREJ & BOYCE MFG. CO. LTD.

Plant 16, Pirojshanagar, Vikhroli, Mumbai 400079.
• Tel: +91 22 6796 4660/ 73 • Fax: +91 22 6796 1519
• E-mail: mhemktg@godrej.com • URL: <http://godrejmh.in>

Overseas Branch and Service Centre,

SAIF Zone, R O. Box 8549, Sharjah, U.A.E.
• Tel: +971 55 8992305/ 2316 • Mob: 00 971 504629701
• Fax: 00 971 65570966 • E-mail: mahesh@godrej.ae

Branches & Service Centres

- Mumbai: 022 67961725 / 67961291
- Pune: 020 66255121-22
- Ahmedabad: 079 66060646 / 66060701 / 66060606
- Indore: 0731 4069335/ 2532917
- Chennai: 044 66544431-32
- Bangalore: 080 66472251
- Kochi: 0484 6612777/ 6612609
- Hyderabad: 040 66431203
- Vizag: 0891 2517930 / 2746511-2-3

- Delhi: 011 66507340/ 50
- Chandigarh: 0172 5012525 / 5037738
- Jaipur: 0141 6701441/ 2
- Lucknow: 0522 6754961
- Kolkata: 033 66013771-75
- Bhubaneswar: 0674 2374626
- Coimbatore: 0422 2545799/ 599
- Guwahati: 03612 468242
- Raipur: 07716606706

To find out more
about what's new at
Godrej Material Handling,
check out
www.godrejmh.in

